

# Scanhugger HT 65/45/2

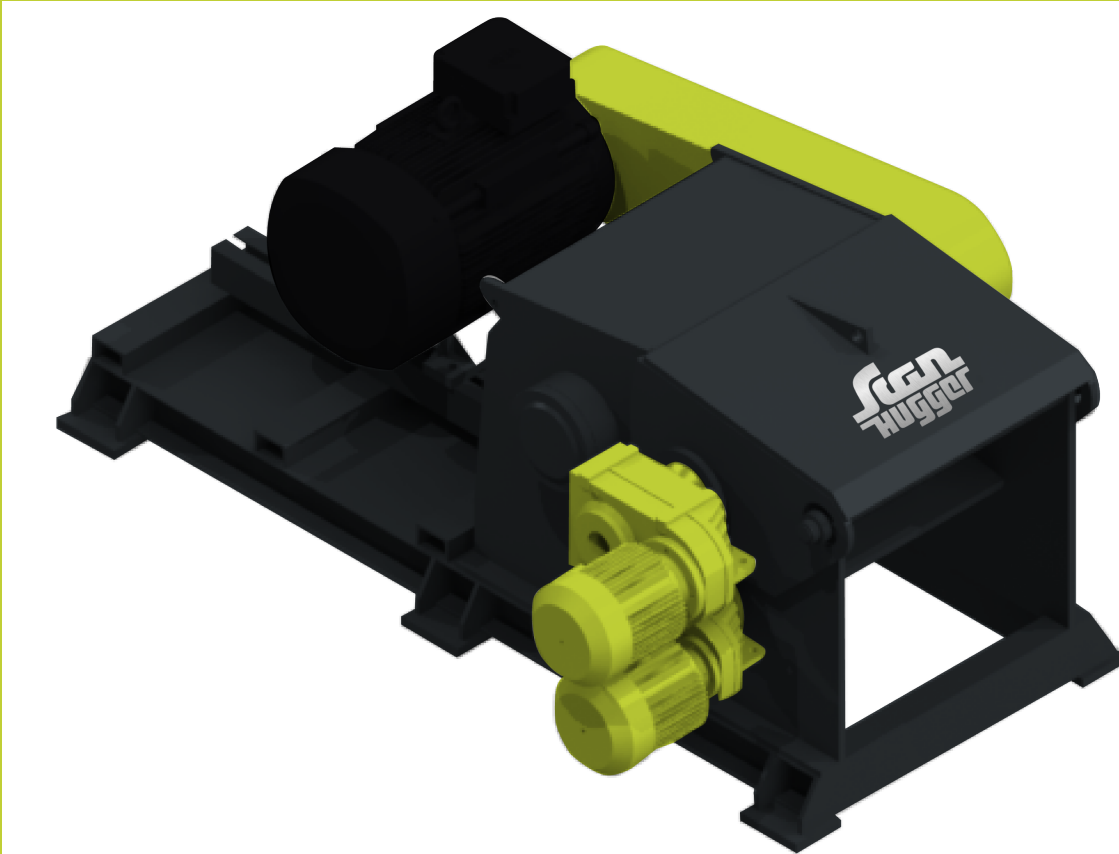

The horizontal shredder is available with two cutting systems. The standard rotor system is a solid, precision machined steel drum ideal for chipping solid wood slabs, edgings, and off-cuts to a defined chip size. The second rotor system is a solid steel drum with a precision mounting arrangement of four-sided knife blocks ideal for processing particleboard, MDF and plywood scrap.

INFEED SIZE

**130 x 630 mm**

INFEED SPEED

**25 - 40 m / min**

ROTOR SPEED

**900 RPM**

ROTOR DIAMETER

**450 mm**

CHIP SIZE

**10 - 30 mm**

MAIN MOTOR

**37 - 75 kW**

WEIGHT

**2900 kg**