

Scanhugger HT 55/30

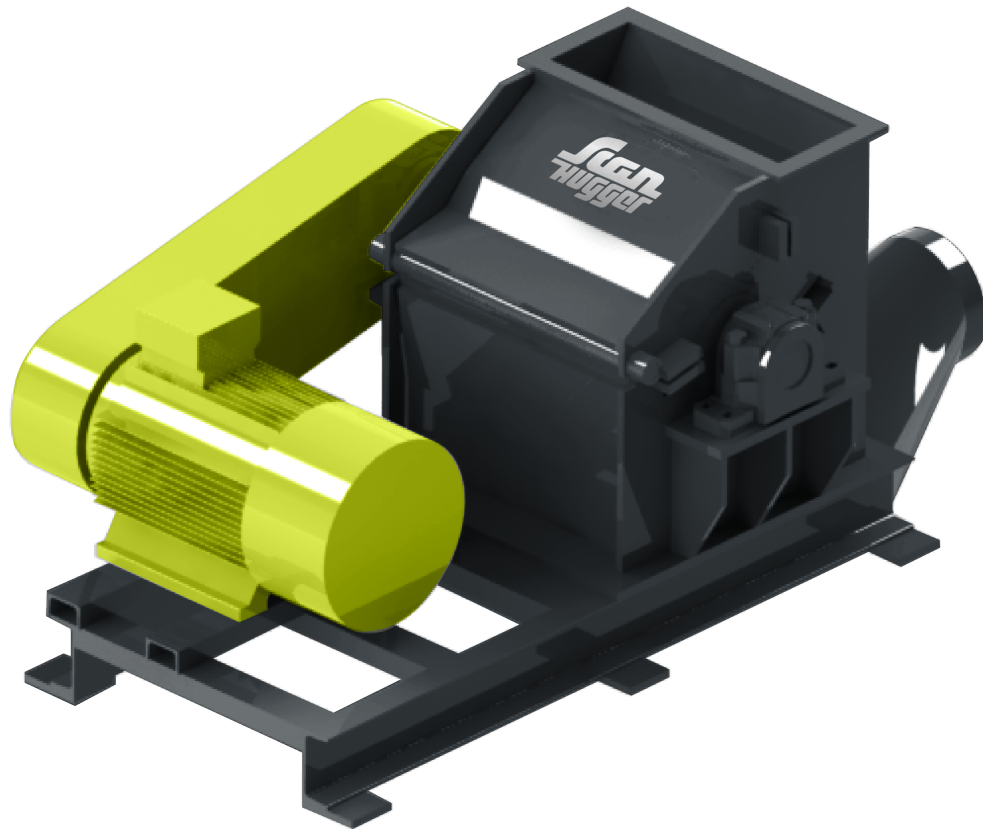

With the secondary shredder from Scanhugger, you'll have a superior granulate that's ideal for briquetting or pellets. With a Scanhugger HT or HL shredder in front of the re-shredder and you'll have a premium product ready for sale, pellets and briquet production. The HT 35/30 re-shredder is available with two different cutting systems.

INFEED SIZE

195 x 550 mm

INFEED SPEED

300 - 1300 m / min

ROTOR SPEED

1750 RPM

ROTOR DIAMETER

350 mm

CHIP SIZE

10 - 30 mm

MAIN MOTOR

30 - 37 kW

WEIGHT

1350 kg

